

VANNE A PAPILLON BUTTERFLY VALVE

Type VPR

Série CSK DV Démultiplicateur à volant sous carter étanche CSK DV serie tight gearbox and handwheel

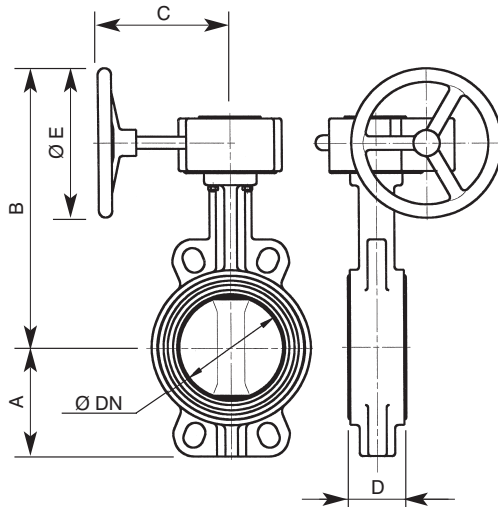

DN	A	B	C	D	E	Kg
32	55	223	173	33	125	6,1
40	55	223		33		6,1
50	62	229		43		6,8
65	70	238		46		7,3
80	89	244		46		7,5
100	106	305	183	52	200	9,3
125	119,5	320		56		11,5
150	130	333		56		12,2
200	163,5	376		60		18,6
250	200	434	287	68	250	32,6
300	232	459	287	78	250	36,4
350	280	556	378	78	400	63

Série CSK E Servomoteur électrique CSK E Serie Electric operator

DN	A	B	C	D	E	Type	Kg
50	62	396	200	43	145	OA6	9
65	70	405		46		OA6	9,5
80	89	411		46		OA6	10
100	106	435	260	52	226	OA8	13
125	119,5	450		56		OA15	16
150	130	463		56		OA15	16,5
200	163,5	483	312	60	226	AS25	34,5
250	200	528	340	68		AS50	46
300	232	553	340	78		AS50	50
350	280	600	343	78		AS80	68

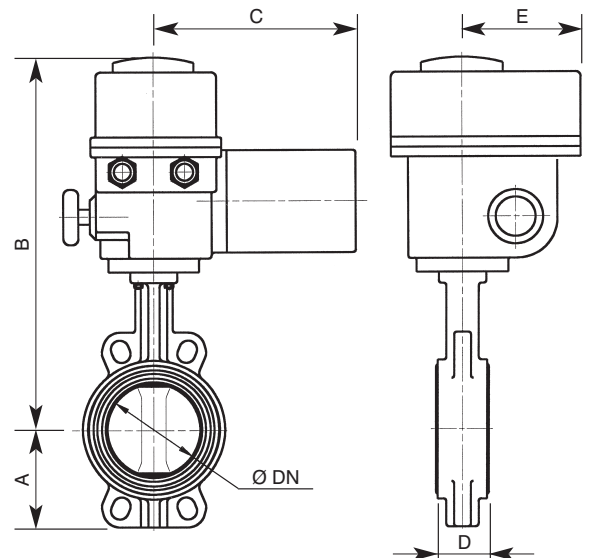

Série CSK DEP Pneumatique double effet CSK DEP serie pneumatic double acting operator

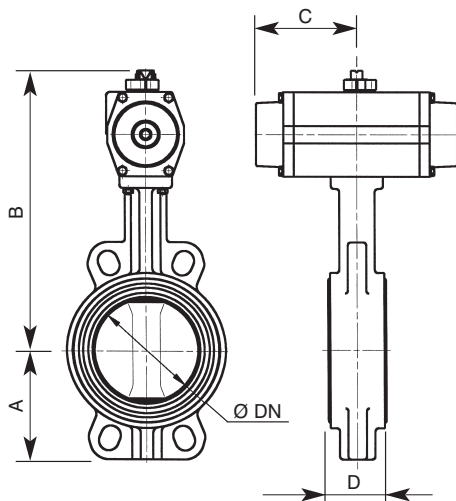

DN	A	B	C	D	Type	Kg
50	62	289	76	43	AT10DA	5
65	70	293	76	46	AT10DA	5,5
80	89	321	101	46	AT20DA	7
100	106	345	101	52	AT20DA	9
125	119,5	370	115	56	AT25DA	12,5
150	130	398	136	56	AT30DA	15
200	163,5	483	154	60	AT35DA	25
250	200	541	180	68	AT40DA	40
300	232	586	190	78	AT45DA	48
350	280	700	288	78	AT60DA	91,5

Indication sans engagement, modifications réservées

Subject to alteration without notice

NOTICE
99021

constructeur
robinetterie industrielle



250, RUE DE LA CURIAZ
73290 LA MOTTE-SERVOLEX
TÉL. 33 (0)4 79 25 17 14
FAX. 33 (0)4 79 25 16 95
URL : <http://www.ramus-industrie.com>

VANNE A PAPILLON BUTTERFLY VALVE

Type VPR

Série CSK axe nu Series CSK bear shaft

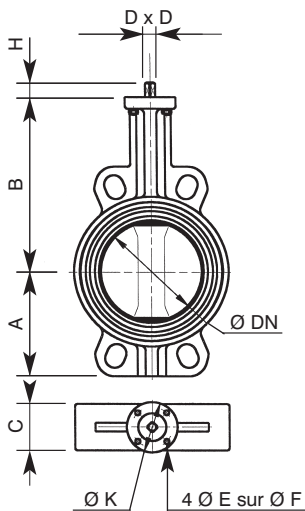

DN	A	B	C	Flange	D x D	H	ØE	ØF	ØK	Poids Kg Weight Kg						
32	55	130	33	F05	11	19	6,5	50	65	1,9						
40	55	130	33							1,9						
50	62	136	43							2,6						
65	70	156	46							3,1						
80	89	151	46							3,3						
100	106	175	52							4,9						
125	119,5	190	56	F07	14	25	8,5	70	90	7,1						
150	130	203	56							7,8						
200	163,5	254,5	60							13,9						
250	200	271	68							F10	22	32	10,5	102	125	22,8
300	232	296	78							F10	22	32	10,5	102	125	26,6

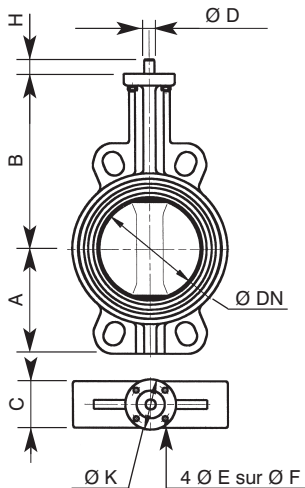

DN	A	B	C	Flange	D	H	ØE	ØF	ØK	Poids Kg Weight Kg
350	280	305	78	F12	28	48	12,5	125	150	42
400	315	338	102	F12	38	63	12,5	125	150	61
450	350	368	114	F14	48	80	17	140	175	85
500	375	403	127	F14	48	80	17	140	175	106
600	438	495	154	F16	58	91	22	165	210	190

Série CSK L : Levier à secteur cranté 5 positions CSK L : serie Lever and 5 positions notch plate

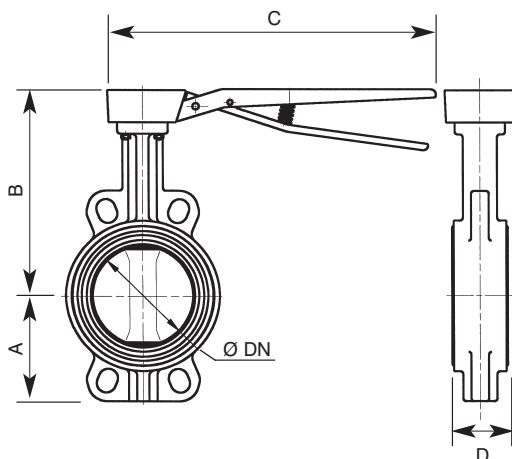

DN	A	B	C	D	Kg
32	55	165	200	33	3,8
40	55	165		33	3,8
50	62	171		43	4,5
65	70	180		46	5
80	93	186		46	6,1
100	110,5	210	290	52	7,8
125	118	225		56	9,7
150	142	238		56	11,3
200	173	307	450	60	20,4
250	204	327		68	32,9
300	234	352		78	44,6

Indication sans engagement, modifications réservées

Subject to alteration without notice

NOTICE
99021

constructeur
robinetterie industrielle



250, RUE DE LA CURIAZ
73290 LA MOTTE-SERVOLEX
TÉL. 33 (0)4 79 25 17 14
FAX. 33 (0)4 79 25 16 95
URL : <http://www.ramus-industrie.com>